

# Soldier Safety and Monitoring System

<sup>[1]</sup>Lokesh Pavan Kumar K, <sup>[2]</sup>Sangeetha K, <sup>[3]</sup>Sree Charan U

<sup>[1][2][3]</sup>Department of ECE, Muthayammal Engineering College, Namakkal, Tamil Nadu, India  
 Corresponding Author Email: <sup>[1]</sup>lokeshyadavkollu@gmail.com, <sup>[2]</sup>sangeethakurupati@gmail.com, <sup>[3]</sup>ulasacharan@gmail.com

**Abstract—** *The Soldier Safety and Monitoring System is a comprehensive solution that enhances battlefield survivability and situational awareness for soldiers. By leveraging a network of wearable sensors, including smartwatches, body sensors, and head-mounted displays, the system continuously monitors soldiers' vital signs, such as heart rate, body temperature, and hydration levels. This data, combined with real-time environmental information like air quality, radiation levels, and chemical threats, is transmitted wirelessly to a central command and control center. Employing advanced PCB Technology, the system analyzes this data stream to identify potential threats, predict health risks, and provide personalized insights into each soldier's physical and cognitive state. This proactive approach enables rapid response to injuries, optimized medical resource allocation, and enhanced soldier well-being. Furthermore, the system provides soldiers with real-time battlefield intelligence, including enemy locations, friendly forces positions, and dynamic threat assessments, significantly improving their situational awareness and decision-making capabilities. By integrating these technologies, the Soldier Safety and Monitoring System aims to minimize the human cost of warfare while ensuring the safety and effectiveness of military personnel.*

**Keywords —** *Soldier Safety, Monitoring System, Battlefield Survivability, Situational Awareness, Wearable Sensors, AI-powered Analytics, Vital Signs, Environmental Hazards, Real-time Intelligence, Rapid Response, Threat Detection, Health Risks, Personalized Insights, Medical Resource Allocation, Soldier Well-being, Battlefield Intelligence, Enemy Locations, Friendly Forces, Decision-Making Capabilities, Human Cost of Warfare, Military Personnel.*

## I. INTRODUCTION

In the world, the Indian army stands second largest force. The role played by the soldier is very important for the nation security. However, the army is suffering from lot of health issues in the remote place due to unavailability of medical treatment at a proper time which may result in the death/loss of the soldier. The lack of communication with the control room regarding the health status and location of the soldier would lead to loss of the soldier too. This can be reduced if the real time information is available to control room as well as another fellow soldier who are nearer to the victim soldier. The cost of the soldier life is very important. During the battle the soldier may accidentally land up in the enemy location without his knowledge, so he may need guidelines to know his current location. Other than the battle field injuries, the soldier may also suffer from extreme climate condition and fall sick, in such situation if care is taken then the life of the soldier would be saved. This can be achieved by using the IOT. The health parameter such as heart rate, ECG and body temperatures are monitored continuously and communicated with the control room automatically. When the soldier feels that he is lost, he can send an emergency message voice message alert to the control room and request for location using an android application which provides the longitude and latitude of the soldier using GPS.

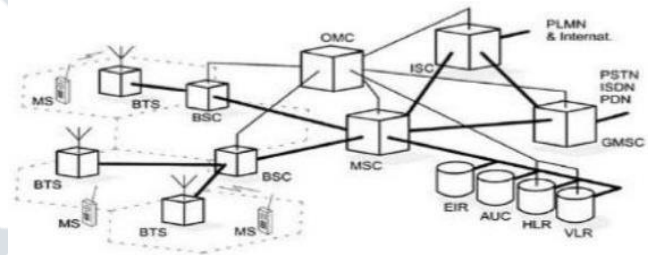

**Figure 1.** Architecture of GSM Technology

Now-a-days Defense Services are rapidly growing towards new innovation with advance implementation. Soldier's health is more important because they are the defenders who protect our country. In today's world enemy warfare is a important factor in the nation's security. The national security mainly depends on army (ground), navy (sea), force (air). The important and vital role is played by the army soldiers. There are many concerns regarding the safety of these soldiers. As soon as any soldier enters the enemy lines. Remote soldier unit and the monitoring center. The portable remote soldier unit consists of Advanced RISC Machines (ARM) with the embedded operating system, GPS and a GSM, temperature sensor and heart beat sensor. To design a soldier tracking system using GSM and GPS to provide wireless system for monitoring the parameters of soldier are as – Body temperature & Blood pressure.

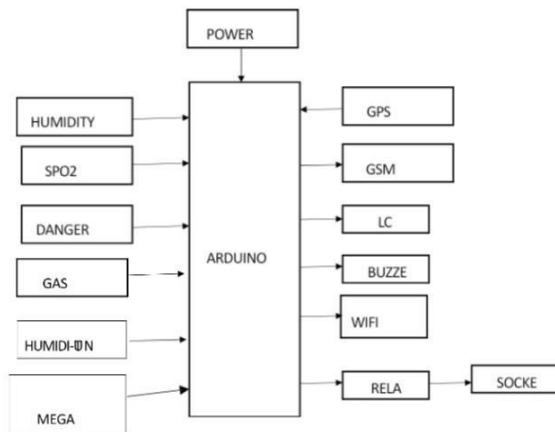

**Figure 2.** Block diagram of Soldier safety and monitoring system

To find the health status of soldier biomedical sensors are used, a body temp sensor to measure body temperature as well as pulse rate sensor to measure the blood pressure. These parameters are then signal conditioned and will be stored in the memory. One of the fundamental challenges in military operations lays in that the Soldier not able to communicate with control room administrator. In addition, each organization needs to enforce certain administrative and operational work when they interact over the network owned and operated by other organizations. Thus, without careful planning and coordination, one troop cannot communicate with the troops or leverage the communication infrastructure operated by the country troops in the same region. to give proper information about location in critical condition. It becomes possible to help the soldier in panic condition by communicating with them by means of GSM. It becomes possible to track those using GPS.

## II. PROPOSED SYSTEM

The digital landscape is undergoing rapid evolution, with the Internet of Things (IoT) emerging as a key driver of change. IoT represents the convergence of software, telecommunications, and electronics, connecting everyday objects to the internet. This interconnectedness fosters new consumer and business behaviors, creating vast opportunities across industries. The number of connected devices has surpassed the global human population, and this trend is projected to accelerate significantly in the coming years. India's initiatives, such as the Smart Cities program and the Digital India Program, are poised to significantly boost IoT adoption within the country.

Smart cities will leverage IoT to enhance various aspects of urban living, including:

- Smart parking
- Intelligent transportation systems
- Tele-care services
- Women's safety initiatives
- Smart grids for energy management

- Efficient waste management systems
- Smart urban lighting solutions
- Digital signage
- Water resource management

Beyond smart cities, IoT has the potential to revolutionize numerous sectors, such as agriculture, healthcare, energy, security, and disaster management. By connecting devices remotely, IoT enables automation and improved efficiency in these domains. Telecom operators and system integrators are actively embracing IoT, recognizing the significant revenue opportunities it represents.

IoT involves three distinct stages:

1. **Data Collection:** Sensors gather data from various sources, including environmental conditions, user behavior, and machine performance.
  2. **Data Processing:** Collected data is transmitted to a central system for analysis and consolidation.
  3. **Decision Making:** Insights derived from data analysis are used to inform decisions and trigger actions, such as adjusting system parameters or alerting relevant personnel.
- i. Effective IoT implementation requires collaboration among key stakeholders, including citizens, the government, and industry players.
    1. Policy frameworks are crucial for promoting IoT adoption and guiding its development.
    2. Prioritizing essential domains and addressing citizen data privacy concerns are paramount.
    3. Building open, scalable, and cost-effective platforms will facilitate widespread IoT adoption.
    4. Citizen participation is essential, with individuals acting as valuable sources of data and feedback.
    5. Fostering innovation through initiatives such as startup engagement is crucial for driving the development of cutting-edge IoT solutions.
  - ii. **Definition and Vision of IoT**
    1. **Definition:** IoT refers to a network of interconnected devices with unique identifiers, enabling machine-to-machine communication without human intervention.
    2. **Vision:** To establish a robust IoT ecosystem in India that contributes to economic growth, societal advancement, environmental sustainability, and global competitiveness.
  - iii. **Objectives of IoT Development in India**
    - To establish a USD 15 billion IoT industry in India by 2020, with a significant increase in connected devices.
    - To develop a skilled workforce with expertise in IoT technologies.
    - To foster research and development in IoT-related technologies.
    - To develop IoT products tailored to specific Indian needs across various sectors.

#### iv. Embedded Systems Involvement

An embedded system is a specialized computer system designed for a specific function within a larger device or system. It typically consists of hardware (microprocessor, memory) and software, often operating in real-time with limited user interaction. Embedded systems are ubiquitous in modern life, found in various devices from automobiles and home appliances to medical equipment and industrial machinery.

#### v. Soldier Safety and Monitoring System

This section describes a proposed system for enhancing soldier safety on the battlefield. The system utilizes a combination of sensors (pulse sensor, temperature sensor, GPS module, GSM module, gas sensor) to monitor soldiers' health, location, and environmental conditions.

#### vi. Hardware and Software Requirements

1. Hardware: Arduino Mega, humidity sensor, pulse sensor, GPS module, GSM module, LCD, buzzer, WiFi module, gas sensor.
2. Software: Arduino IDE, C programming language.

### III. CONCLUSION

The Internet of Things (IoT) is poised to revolutionize numerous aspects of our lives, from smart homes and cities to industrial automation and healthcare. By connecting everyday objects to the internet, IoT fosters unprecedented levels of connectivity and data exchange, enabling innovative solutions to complex challenges. As IoT continues to evolve, it is crucial to address key considerations such as data privacy, security, and interoperability to ensure its responsible and beneficial integration into society.

### REFERENCES

- [1] "IOT BASED HEALTH AND POSITION TRACKING SYSTEM FOR SOLDIER SECURITY SYSTEM" Rajitha m, s. Madhava l. Vol 13, issue 06, June, 2022, issue no 03779254.
- [2] Teja, Krishna, et al. "Smart Soldier Health Monitoring System Incorporating Embedded Electronics." *Advances in VLSI and Embedded Systems*. Springer, Singapore, 2021. 223-23.
- [3] Jethwa, Bhargav, et al. "Realtime soldier's health monitoring system incorporating low power LoRa communication." *International Journal of Sensor Networks* 35.4 (2021): 221- 229.
- [4] Kavitha, D., and S. Ravikumar. "IOT and context-aware learning-based optimal neural network model for real-time health monitoring." *Transactions on Emerging Telecommunications Technologies* 32.1 (2021): e4132.
- [5] D. Poorna Kumar, R. Periyanyaki, M. R. Pradheepa, N. Prakash Kumar and S Nandhini "Soldiers Navigation and Health Monitoring System using GPS and GSM", *International Journal of Research in Engineering Science and Management*, Volume No: 3, Issue: 4, pp:115- 158, April-2020.
- [6] Zeeshan Raza, Kumaran Liaquat and Shahrazad Ashraf, "Monitoring of soldier health and transmission of secret codes", *NFC institution of Engineering*, vol. 8, no. 2, June 2017.
- [7] Shubhangi Gupta, Shivani Kulshrestha, Divya Singh, Ashish Kumar and Hitendra Singh, *GPS and GSM based soldier health monitoring and tracking system*, no. 3.
- [8] Ravindra B. Sathe and A.S. Bhide, Gps-based soldier tracking and health monitoring system.
- [9]. Rahul Jain, Nikhil Wyawahare and Arpit Doshi, "Detection of Component Assembly Error using Computer Vision: A Review", *International Journal of Innovative Technology an Exploring Engineering (IJITEE)*, vol. 9, no. 10, August 2020, ISSN 2278–3075.